

LMI Methods in Optimal and Robust Control

Matthew M. Peet
Arizona State University

Lecture 08: The Optimal Control Framework

2-input 2-output Framework



We introduce the control framework by separating internal signals from external signals.

Output Signals:

- **z :** Output to be controlled/minimized
 - ▶ Regulated output
- **y :** Output used by the controller
 - ▶ Must be measured in real-time by sensor
 - ▶ May replicate signals from regulated output

2-input 2-output Framework



Input Signals:

- **w :** Disturbance, Tracking Signal, etc.
 - ▶ exogenous input
- **u :** Output from controller
 - ▶ Input to actuator
 - ▶ Not related to external input

The Optimal Control Framework

The controller closes the loop from y to u .

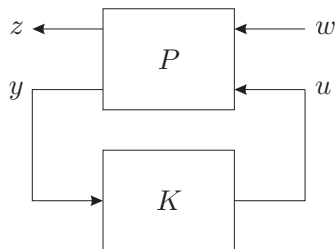

For a linear system P , we have 4 subsystems.

$$\begin{bmatrix} z \\ y \end{bmatrix} = \begin{bmatrix} P_{11} & P_{12} \\ P_{21} & P_{22} \end{bmatrix} \begin{bmatrix} w \\ u \end{bmatrix}$$

All P_{ij} are MIMO

$$P_{11} : w \mapsto z$$

$$P_{12} : u \mapsto z$$

$$P_{21} : w \mapsto y$$

$$P_{22} : u \mapsto y$$

The Optimal Control Framework

The controller closes the loop from y to u .For a linear system P , we have 4 subsystems.

$$\begin{bmatrix} z \\ y \end{bmatrix} = \begin{bmatrix} P_{11} & P_{12} \\ P_{21} & P_{22} \end{bmatrix} \begin{bmatrix} u \\ w \end{bmatrix}$$

All P_{ij} are MIMO

$$P_{11} : w \rightarrow z$$

$$P_{12} : u \rightarrow z$$

$$P_{21} : w \rightarrow y$$

$$P_{22} : u \rightarrow y$$

Note that systems, like matrices, are also closed under **Concatenation**. That is, we can stack them horizontally or vertically.

Note also the signals move right to left. This makes it easier to read the block diagram as an equation of the form

$$LHS = RHS$$

The Regulator

First Step: Formulate the control problem in the 2-input/2-output framework.

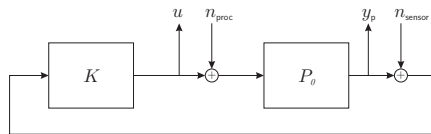

If we define

$$z_2 = u$$

$$q = w_1 + u$$

$$z_1 = y_p$$

$$y = r + w_2$$

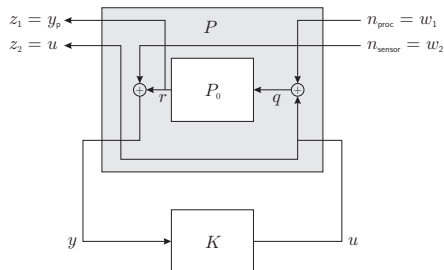

The Regulator

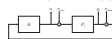

If we define

$$z_1 = u_1 \quad y = W_1 u + w$$

$$z_2 = W_2 u \quad y = r + W_2$$

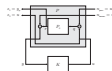

We use a Regulator when we are trying to suppress the effect of disturbances on outputs of the system.

The Regulator

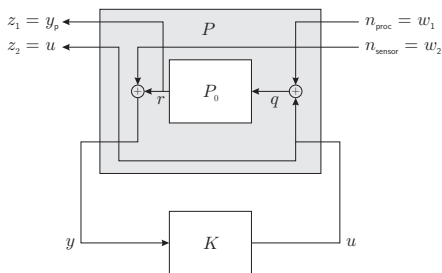

The reconfigured plant P is given by

If $P_0 = (A, B, C, D)$, then

$$\begin{bmatrix} z_1(t) \\ z_2(t) \\ y(t) \end{bmatrix} = \underbrace{\begin{bmatrix} P_0 & 0 & P_0 \\ 0 & 0 & I \\ P_0 & I & P_0 \end{bmatrix}}_P \begin{bmatrix} w_1(t) \\ w_2(t) \\ u(t) \end{bmatrix}$$

$$P = \left[\begin{array}{c|ccc} A & B & 0 & B \\ \hline C & D & 0 & D \\ 0 & 0 & 0 & I \\ C & D & I & D \end{array} \right]$$

The Regulator

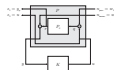

The reconfigured plant P is given by

$$\begin{bmatrix} z_1(t) \\ z_2(t) \\ y(t) \end{bmatrix} = \begin{bmatrix} P_0 & 0 & P_0 \\ 0 & 0 & I \\ P_0 & I & P_0 \end{bmatrix} \begin{bmatrix} w_1(t) \\ w_2(t) \\ u(t) \end{bmatrix}$$

If $P_0 = (A, B, C, D)$, then

$$P = \begin{bmatrix} A & B & 0 & B \\ C & D & 0 & D \\ C & D & I & D \end{bmatrix}$$

Note also that getting from

$$\begin{bmatrix} P_0 & 0 & P_0 \\ 0 & 0 & I \\ P_0 & I & P_0 \end{bmatrix}$$

to

$$P = \left[\begin{array}{c|ccc} A & B & 0 & B \\ \hline C & D & 0 & D \\ 0 & 0 & 0 & I \\ C & D & I & D \end{array} \right]$$

is not an algebraic operation.

If we were using *Transfer Functions*, however, we could use the algebraic representation.

Diagnostics

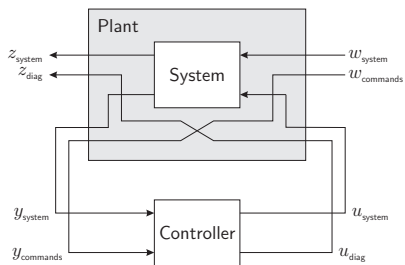
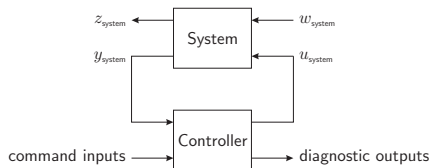

Tracking Control

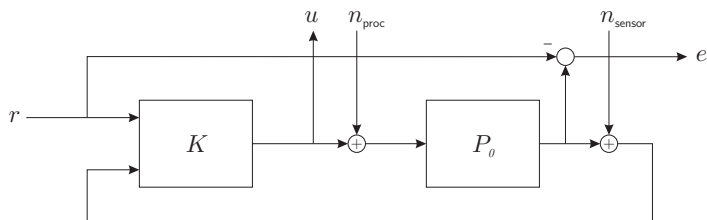

$r =$ tracking input

$e =$ tracking error

$n_{proc} =$ process noise

$n_{sensor} =$ sensor noise

$w_2 = n_{proc}$

$w_3 = n_{sensor}$

$z_1 = e$

$z_2 = u$

$w_1 = r$

$u = u$

$y_1 = r$

$y_2 = y_p$

Tracking Control

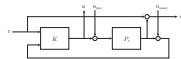

r == tracking input w_2 == $w_{process}$ w_3 == r
 e == tracking error w_3 == $w_{measurement}$ w_1 == w
 $w_{process}$ == process noise z_1 == e z_1 == r
 $w_{measurement}$ == sensor noise z_2 == w z_2 == w_p

- When using the Tracing Framework we *do not* want the output of the nominal plant to be zero.
- Instead we want the difference between the nominal output and the reference to be zero.
- In the optimal control framework, we always want the output (z) of the enlarged plant P to be zero.

Tracking Control

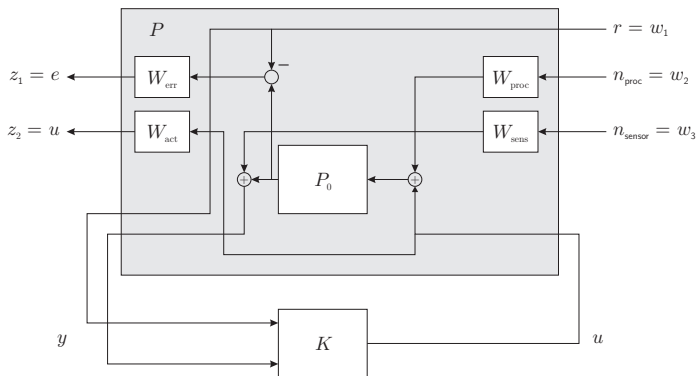

$$P = \begin{bmatrix} I & -P_0 & 0 & -P_0 \\ 0 & 0 & 0 & I \\ I & 0 & 0 & 0 \\ 0 & P_0 & I & P_0 \end{bmatrix}$$

$$z_1 = r - P_0(n_{proc} + u)$$

$$z_2 = u$$

$$y_1 = r$$

$$y_2 = w_3 + P_0(n_{proc} + u)$$

Lecture 08

2020-10-18

Tracking Control

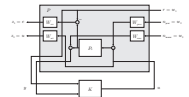

$$P = \begin{bmatrix} I & -P_0 & 0 & -P_1 \\ 0 & 0 & 0 & I \\ I & 0 & 0 & 0 \\ 0 & P_0 & I & P_1 \end{bmatrix} \quad \begin{aligned} z_1 &= r - P_0(n_{p+1} + u) \\ z_2 &= u \\ y_1 &= r \\ y_2 &= u_2 + P_1(n_{p+1} + u) \end{aligned}$$

Note the treatment of systems as algebraic objects

Linear Fractional Transformation

Close the loop

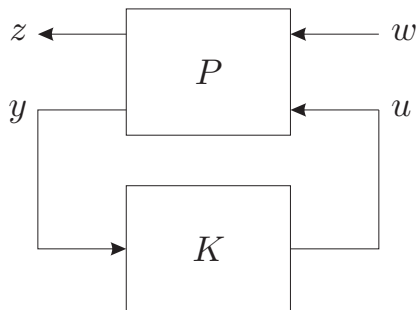

Plant:

$$\begin{bmatrix} z \\ y \end{bmatrix} = \begin{bmatrix} P_{11} & P_{12} \\ P_{21} & P_{22} \end{bmatrix} \begin{bmatrix} w \\ u \end{bmatrix} \quad \text{where} \quad P = \left[\begin{array}{c|cc} A & B_1 & B_2 \\ \hline C_1 & D_{11} & D_{12} \\ C_2 & D_{21} & D_{22} \end{array} \right]$$

Controller:

$$u = Ky \quad \text{where} \quad K = \left[\begin{array}{c|c} A_K & B_K \\ \hline C_K & D_K \end{array} \right]$$

Linear Fractional Transformation

$$z = P_{11}w + P_{12}u$$

$$y = P_{21}w + P_{22}u$$

$$u = Ky$$

Solving for u ,

$$u = KP_{21}w + KP_{22}u$$

Thus

$$(I - KP_{22})u = KP_{21}w$$

$$u = (I - KP_{22})^{-1}KP_{21}w$$

Now we solve for z :

$$z = [P_{11} + P_{12}(I - KP_{22})^{-1}KP_{21}] w$$

Linear Fractional Transformation

This expression is called the Linear Fractional Transformation of (P, K) , denoted

$$\underline{S}(P, K) := P_{11} + P_{12}(I - KP_{22})^{-1}KP_{21}$$

AKA: Lower Star Product

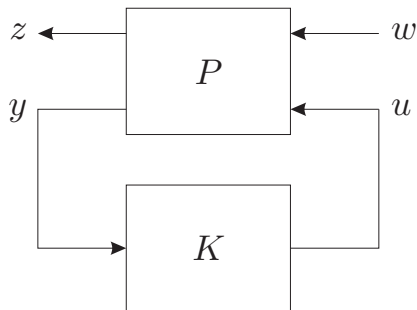

Other Fractional Transformations

Lower LFT:

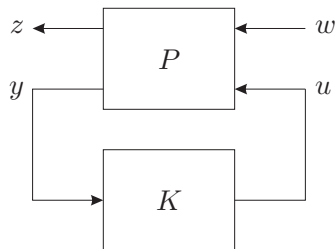

$$\underline{S}(P, K) := P_{11} + P_{12}(I - KP_{22})^{-1}KP_{21}$$

Upper LFT:

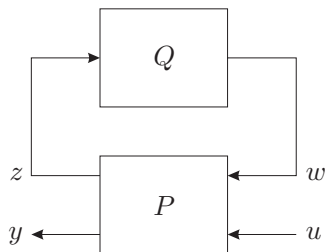

$$\bar{S}(P, K) := P_{22} + P_{21}Q(I - P_{11}Q)^{-1}P_{12}$$

Other Fractional Transformations

Star Product:

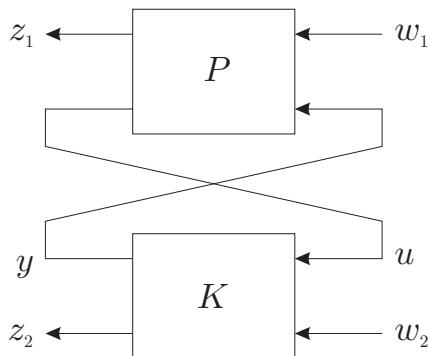

$$S(P, K) := \begin{bmatrix} \underline{S}(P, K_{11}) & P_{12}(I - K_{11}P_{22})^{-1}K_{12} \\ K_{21}(I - P_{22}K_{11})^{-1}P_{21} & \bar{S}(K, P_{22}) \end{bmatrix}$$

The interconnection doesn't always make sense.

Definition 1.

The interconnection $\underline{S}(P, K)$ is **well-posed** if for any smooth w and any $x(0)$ and $x_K(0)$, there exist functions x, x_K, u, y, z such that

$$\begin{aligned}\dot{x}(t) &= Ax(t) + B_1w(t) + B_2u(t) & \dot{x}_K(t) &= A_Kx_K(t) + B_Ky(t) \\ z(t) &= C_1x(t) + D_{11}w(t) + D_{12}u(t) & u(t) &= C_Kx_K(t) + D_Ky(t) \\ y(t) &= C_2x(t) + D_{21}w(t) + D_{22}u(t)\end{aligned}$$

Note: The solution does not need to be in L_2 .

- Says nothing about stability.

Well-Posedness

- State-space systems always have a solution.
- If there is a state-space representation of the closed-loop system, the interconnection is well-posed.
- If we were to use the Transfer Function representation, we would be looking at whether the closed-loop TF is rational and proper
- There exists a system-level version of well-posedness, but requires us to define the extended space L_{2e} of functions integrable on finite intervals. (needed for passivity, IQCs, etc.)

The interconnection doesn't always make sense.

Definition 1.

The interconnection $\mathbb{G}(P, K)$ is **well-posed** if for any smooth w and any $x(0)$ and $x_K(0)$, there exist functions x, x_K, u, y, z such that

$$\begin{aligned} \dot{x}(t) &= Ax(t) + B_{1w}(t) + B_{2u}(t) & \dot{x}_K(t) &= A_K x_K(t) + B_K y(t) \\ z(t) &= C_z x(t) + D_{z1} w(t) + D_{z2} u(t) & u(t) &= C_K x_K(t) + D_K y(t) \\ y(t) &= C_y x(t) + D_{y1} w(t) + D_{y2} u(t) & & \end{aligned}$$

Note: The solution does not need to be in L_2 .

- Says nothing about stability.

Well-Posedness

In state-space format:

$$\begin{bmatrix} \dot{x}(t) \\ \dot{x}_K(t) \end{bmatrix} = \begin{bmatrix} A & 0 \\ 0 & A_K \end{bmatrix} \begin{bmatrix} x(t) \\ x_K(t) \end{bmatrix} + \begin{bmatrix} B_2 & 0 \\ 0 & B_K \end{bmatrix} \begin{bmatrix} u(t) \\ y(t) \end{bmatrix} + \begin{bmatrix} B_1 \\ 0 \end{bmatrix} w(t)$$
$$z(t) = \begin{bmatrix} C_1 & 0 \end{bmatrix} \begin{bmatrix} x(t) \\ x_K(t) \end{bmatrix} + \begin{bmatrix} D_{12} & 0 \end{bmatrix} \begin{bmatrix} u(t) \\ y(t) \end{bmatrix} + D_{11}w(t)$$

From

$$u(t) = D_K y(t) + C_K x_K(t)$$
$$y(t) = D_{22}u(t) + C_2 x(t) + D_{21}w(t),$$

we have

$$\begin{bmatrix} I & -D_K \\ -D_{22} & I \end{bmatrix} \begin{bmatrix} u(t) \\ y(t) \end{bmatrix} = \begin{bmatrix} 0 & C_K \\ C_2 & 0 \end{bmatrix} \begin{bmatrix} x(t) \\ x_K(t) \end{bmatrix} + \begin{bmatrix} 0 \\ D_{21} \end{bmatrix} w(t).$$

Because the rest is state-space, the interconnection is well-posed if and only if the matrix $\begin{bmatrix} I & -D_K \\ -D_{22} & I \end{bmatrix}$ is invertible.

Well-Posedness

Question: When is

$$\begin{bmatrix} I & -D_K \\ -D_{22} & I \end{bmatrix}$$

invertible?

Answer: 2x2 matrices have a closed-form inverse

$$\begin{bmatrix} I & -D_K \\ -D_{22} & I \end{bmatrix}^{-1} = \begin{bmatrix} I + D_K Q D_{22} & D_K Q \\ Q D_{22} & Q \end{bmatrix}$$

where $Q = (I - D_{22} D_K)^{-1}$.

Proposition 1.

The interconnection $\underline{S}(P, K)$ is well-posed if and only if $(I - D_{22} D_K)$ is invertible.

- Equivalently $(I - D_K D_{22})$ is invertible.
- Sufficient conditions: $D_K = 0$ or $D_{22} = 0$.
- To optimize over K , we will need to enforce this constraint somehow.

Well-Posedness

Question: When is

$$\begin{bmatrix} I & -D_K \\ -D_{22} & I \end{bmatrix}$$

invertible?

Answer: 2×2 matrices have a closed-form inverse

$$\begin{bmatrix} I & -D_K \\ -D_{22} & I \end{bmatrix}^{-1} = \begin{bmatrix} I + D_K Q D_{22} & D_K Q \\ Q D_{22} & Q \end{bmatrix}$$

where $Q = (I - D_{22} D_K)^{-1}$.**Proposition 1.**The interconnection $\underline{S}(P, K)$ is well-posed if and only if $(I - D_{22} D_K)$ is invertible.

- Equivalently $(I - D_K D_{22})$ is invertible.
- Sufficient conditions: $D_K = 0$ or $D_{22} = 0$.
- To optimize over K , we will need to enforce this constraint somehow.

- The Simplest example of a system which is not well-posed is interconnection of matrices $D_K = I$ and $D_{22} = I$.
- This corresponds to audio feedback (Larsen Effect) when a microphone and speaker are placed next to each other.

We now have the state-space representation of $\underline{S}(P, K)$.

$$\begin{bmatrix} \dot{x}(t) \\ \dot{x}_K(t) \end{bmatrix} = \left(\begin{bmatrix} A & 0 \\ 0 & A_K \end{bmatrix} + \begin{bmatrix} B_2 & 0 \\ 0 & B_K \end{bmatrix} \begin{bmatrix} I & -D_K \\ -D_{22} & I \end{bmatrix}^{-1} \begin{bmatrix} 0 & C_K \\ C_2 & 0 \end{bmatrix} \right) \begin{bmatrix} x(t) \\ x_K(t) \end{bmatrix} \\ + \begin{bmatrix} B_1 + B_2 D_K Q D_{21} \\ B_K Q D_{21} \end{bmatrix} w(t)$$

$$z(t) = \left(\begin{bmatrix} C_1 & 0 \end{bmatrix} + \begin{bmatrix} D_{12} & 0 \end{bmatrix} \begin{bmatrix} I & -D_K \\ -D_{22} & I \end{bmatrix}^{-1} \begin{bmatrix} 0 & C_K \\ C_2 & 0 \end{bmatrix} \right) \begin{bmatrix} x(t) \\ x_K(t) \end{bmatrix} \\ + (D_{11} + D_{12} D_K Q D_{21}) w(t)$$

where $Q = (I - D_{22} D_K)^{-1}$

Definition 2.

The **Optimal H_∞ -Control Problem** is

$$\min_{K \in H_\infty} \|\underline{S}(P, K)\|_{H_\infty} = \|\underline{S}(P, K)\|_{\mathcal{L}(L_2)}$$

- Also Optimal H_∞ dynamic-output-feedback Control Problem

Definition 3.

The **Optimal H_2 -Control Problem** is

$$\min_{K \in H_\infty} \|\underline{S}(P, K)\|_{H_2} \quad \text{such that}$$
$$\underline{S}(P, K) \in H_\infty.$$

Optimal Control

Choose K to minimize

$$\|P_{11} + P_{12}(I - KP_{22})^{-1}KP_{21}\|_{H_\infty}$$

Equivalently choose $\left[\begin{array}{c|c} A_K & B_K \\ \hline C_K & D_K \end{array} \right]$ to minimize

$$\left\| \left[\begin{array}{c|c} \left[\begin{array}{cc} A & 0 \\ 0 & A_K \end{array} \right] + \left[\begin{array}{cc} B_2 & 0 \\ 0 & B_K \end{array} \right] \left[\begin{array}{cc} I & -D_K \\ -D_{22} & I \end{array} \right]^{-1} \left[\begin{array}{cc} 0 & C_K \\ C_2 & 0 \end{array} \right] & \begin{array}{c} B_1 + B_2 D_K Q D_{21} \\ B_K Q D_{21} \end{array} \\ \hline \left[\begin{array}{cc} C_1 & 0 \end{array} \right] + \left[\begin{array}{cc} D_{12} & 0 \end{array} \right] \left[\begin{array}{cc} I & -D_K \\ -D_{22} & I \end{array} \right]^{-1} \left[\begin{array}{cc} 0 & C_K \\ C_2 & 0 \end{array} \right] & D_{11} + D_{12} D_K Q D_{21} \end{array} \right\|_{H_\infty}$$

where $Q = (I - D_{22}D_K)^{-1}$.

In either case, the problem is **Nonlinear**.

Optimal Control

Choose K to minimize

$$\|P_{11} + P_{12}(I - K P_{22})^{-1} K P_{21}\|_{\infty}$$

Equivalently choose $\begin{bmatrix} A_k & B_k \\ C_k & D_k \end{bmatrix}$ to minimize

$$\left\| \begin{bmatrix} \begin{bmatrix} A & 0 \\ 0 & A_k \end{bmatrix} & \begin{bmatrix} B_1 & 0 \\ 0 & B_k \end{bmatrix} & \begin{bmatrix} I & -D_{11} \\ -D_{12} & I \end{bmatrix}^{-1} & \begin{bmatrix} 0 & C_1 \\ C_k & 0 \end{bmatrix} & \begin{bmatrix} B_1 + B_1 D_{11} Q D_{11} \\ B_k Q D_{11} \end{bmatrix} \\ \begin{bmatrix} C_1 & 0 \end{bmatrix} + [D_{11} & 0] & \begin{bmatrix} I & -D_{11} \\ -D_{12} & I \end{bmatrix} & \begin{bmatrix} 0 & C_k \\ C_1 & 0 \end{bmatrix} & \begin{bmatrix} D_{11} + D_{11} D_{11} Q D_{11} \end{bmatrix} \end{bmatrix}$$

where $Q = (I - D_{11} D_{11})^{-1}$.In either case, the problem is **Nonlinear**.

There are 3 ways to linearize this problem.

- A change of variables and the Coprime factorization/Youla parameterization approach (Not discussed, but introduced)
- The special case of static full-state feedback (Also a change of variables).
- A change of variables in the dynamic output feedback case.

Optimal Control

There are several ways to address the problem of nonlinearity.

$$\|P_{11} + P_{12}(I - KP_{22})^{-1}KP_{21}\|_{H_\infty}$$

Variable Substitution: The easiest way to make the problem linear is by declaring a new variable $R := (I - KP_{22})^{-1}K$

The optimization problem becomes: Choose R to minimize

$$\|P_{11} + P_{12}RP_{21}\|_{H_\infty}$$

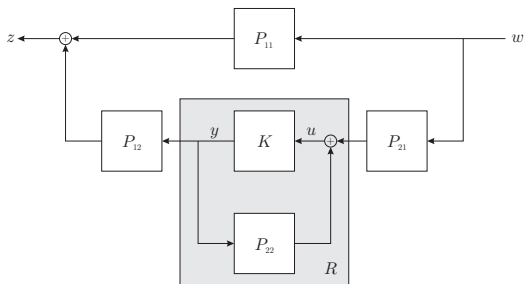

Optimal Control

We optimize

$$\|P_{11} + P_{12}(I - KP_{22})^{-1}KP_{21}\|_{H_\infty} = \|P_{11} + P_{12}RP_{21}\|_{H_\infty}$$

Once, we have the optimal R , we can recover the optimal K as

$$K = R(I + RP_{22})^{-1}$$

Problems:

- how to optimize $\|\cdot\|_{H_\infty}$.
- Is the controller stable?
 - ▶ Does the inverse $(I + RP_{22})^{-1}$ exist? Yes.
 - ▶ Is it a bounded linear operator?
 - ▶ In which space?
- An important branch of control.
 - ▶ Coprime factorization
 - ▶ Youla parameterization
- We will sidestep this body of work.